



# STAR-MAX™ ELECTRIC HOT PLATES

## Model 502D & 502FD

Star-Max™ Electric Hot Plates

### Features/Benefits:

#### Model 502D Coil Type

- ★ Removable coil-type incoloy sheath tubular elements in independent infinite controls for precise temperature control.
- ★ Stainless steel bullnose front provides knob protection and comfortable work zone.
- ★ A compact 12" width to fit almost anywhere.
- ★ Convenient lift out drip pan makes cleaning easy.
- ★ Heavy-duty 4" adjustable legs to match the height of other Star-Max™ equipment in your line.

#### Model 502FD Solid Top (French Style)

- ★ Sealed cast iron elements provide a solid flat surface for faster even heating.
- ★ Independent controls for precise temperature control.
- ★ Stainless steel bullnose front provides knob protection and comfortable work zone.
- ★ Solid top prevents spills from entering unit and makes clean-up and maintenance fast and easy.
- ★ A compact 12" width to fit almost anywhere.
- ★ Heavy-duty 4" adjustable legs to match the height of other Star-Max™ equipment in your line.



Model 502D

### Applications:

Star's two-burner hot plates are designed for a variety of operations. Perfect for warming, cooking or sauteing, Star-Max hot plates will fulfill your cooking requirements.

### Quality Construction:

Model 502D and 502FD Hot Plates are constructed with stainless steel top, front panel and bullnose. Aluminized steel side and crumb tray with black polycarbonate trim on front panels. The hot plates operate on 208 or 240 volts and are equipped with a junction box at the rear for making electrical connections. Both units feature infinite controls with 2 pilot lights.

### Warranty:

Star-Max™ electric hot plates are covered by Star's one year parts and labor warranty.



Model 502FD





## STAR-MAX™ ELECTRIC HOT PLATES Model 502D & 502FD

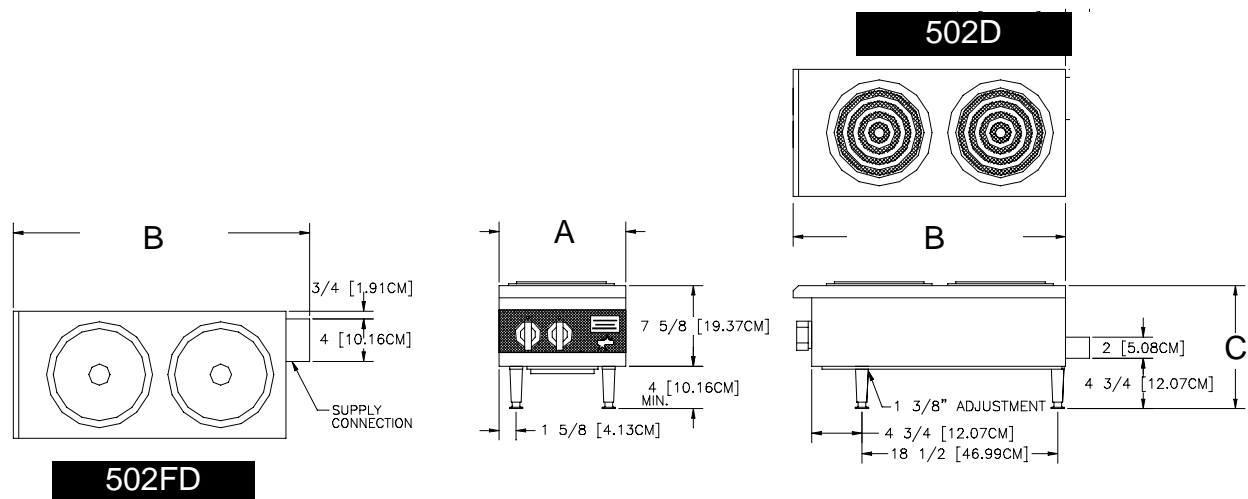

### Specifications

Model No.	Dimensions			Cooking Surface Height Inches (cm)	Approximate Weight	
	(A) Width Inches (cm)	(B) Depth Inches (cm)	(C) Height Inches (cm)		Installed lbs (kg)	Shipping lbs (kg)
502D	12 (30.5)	28 (71.1)	11-5/8 (29.5)	11-5/8 (29.5)	30 (13.6)	40 (18.1)
502FD	12 (30.5)	28 (71.1)	11-5/8 (29.5)	11-5/8 (29.5)	35 (15.9)	45 (20.4)

4" (10.16 cm) legs with 1-3/8" (3.5 cm) adjustment

### Electrical Data

Model No.	Rated Wattage		Nominal Amps - Single Phase	
	208V	240V	208V	240V
502D	3150	4200	15.1	17.5
502FD	3900	5200	18.8	21.6

### Typical Specifications

Electric hot plates are constructed of aluminized steel with stainless top and front and feature black polycarbonate trim. Units are equipped with infinite controls, 2 pilot lights, and are available with incoloy sheath tubular elements or sealed cast iron elements. Hot plates have a junction box at the rear of the unit and operate on 208V or 240V. Units carry the approval of Underwriters' Laboratories, NSF listed and CSA approved. Printed in the U.S.A.

Star Manufacturing International Inc. - 10 Sunnen Drive - P.O. Box 430129 - St. Louis, MO 63143-3800

Phone: (800) 264-7827 - FAX: (800) 264-6666 - www.star-mfg.com