



Classic Countertop Round Cooker/Warmers

Model: RCW-7 RCW-11

PRODUCT:

QUANTITY:

ITEM#:

Designed Smart.

- Both models have heating elements that evenly distribute heat throughout the unit.
- Thermostatically controlled heat can reach intense temperatures that produce consistent steam heat (212°).
- Units are designed with high wattage systems that generate faster start-ups to the required temperatures.
- RCW-7 has 1000 Watts.
- RCW-11 has 1200 Watts.
- Provided with insulation to protect interior parts and countertops from heat build-up.
- Cooker/Warmers are ideal for thawing frozen soups and holding the thawed soup at NSF-safe serving temperatures.



7 Quart

RCW-7 COUNTERTOP ROUND COOKER/WARMER



11 Quart

RCW-11 COUNTERTOP ROUND COOKER/WARMER

Built Solid.

Built to Last

- Round Cooker/Warmers are constructed with heavy-duty stainless steel for long life.
- Interior liner made of tough stainless steel.

Reliability backed by the Industry's Best Warranty

- This APW Wyott Warming Equipment is backed by a 1-year Parts and Labor warranty, including our "Enhanced Warranty" service that replaces new units with certain product issues through the convenience of direct factory shipments.



- Certified by the following agencies:



Option:

- Special Packages Includes Inset and Ladle

APW Wyott Design Features

- 7 qt. (RCW-7) or 11 qt. (RCW-11) capacity.
- Stainless steel housing with stainless steel liner.
- Thermostatic control.
- Raised liner edge (marine lip) prevents outside condensation.
- Electric low watt density element provides fast, even heat.
- Wet or dry operation.
- Uses standard insets and covers (not included).

See reverse side for product specifications.



APW Wyott Foodservice Equipment Company

729 Third Avenue • Dallas, TX 75226 • 800-527-2100 • 1-214-421-7366 • Fax 1-214-565-0976

For more information e-mail us at: Info@APWwyott.com

Rev. 1/1/2003



Classic Countertop Round Cooker/Warmers

Model: RCW-7 RCW-11

PRODUCT:

QUANTITY:

ITEM#:

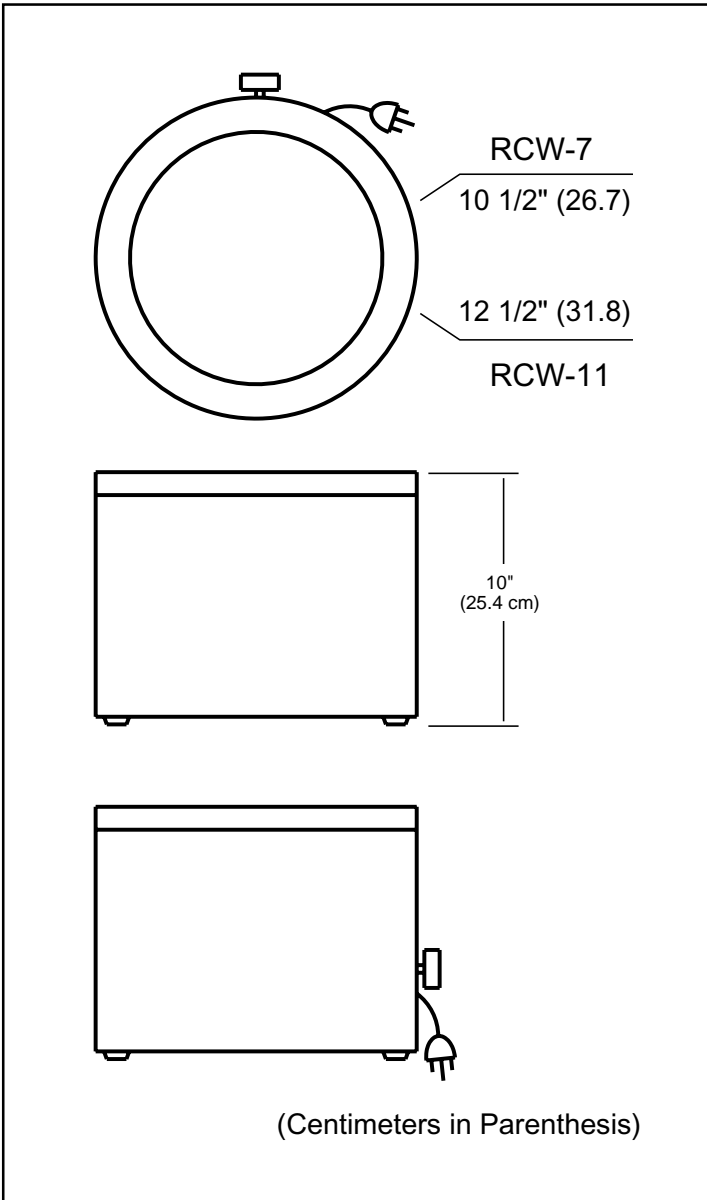

PRODUCT SPECIFICATIONS

Construction:

Stainless steel housing and liner, and fiberglass insulation.

Dimensions:

RCW-7: Diameter 10 1/2" (26.7 cm)

Height 10" (25.4 cm)

RCW-11: Diameter 12 1/2" (31.8 cm)

Height 10" (25.4 cm)

Electrical Information:

Each unit is equipped with a 60", three wire grounded power cord which terminates with a standard three pronged male plug. The 120V unit uses a NEMA 5-15P plug.

Electrical Specifications:

RCW-7: 120V, 1000W, 8.3 Amps

RCW-11: 120V, 1200W, 10.0 Amps

Capacity:

RCW-7: 7 qts. (6.6 L)

Holds a standard 7 quart inset.

RCW-11: 11 qts. (10.4 L)

Holds a standard 11 quart inset.

Ship Weight:

	<u>Standard</u>	<u>Special Pkg.*</u>
RCW-7:	10 lbs. (4.54 kg)	11 lbs. (5 kg)
RCW-11:	12 lbs. (5.45kg)	13 lbs. (5.9 kg)

*Special package contains inset, hinged cover and ladle.

F.O.B./ Dallas, TX

APW WYOTT "Enhanced Warranty" Program

For equipment covered by APW Wyott's "Enhanced Warranty" program—if within one year from the date of purchase, this unit fails to function, you are entitled to your choice of 1,2 or 3.

1. APW Wyott will replace the unit.
2. You may take this unit to the APW Wyott Authorized Service

Distributor.

3. You can request the Authorized Service Distributor to service the equipment on site.

24-HOUR SERVICE HOTLINE: 1-800-733-2203

Please see—page 17 of the 2002 APW Wyott Price list for program details.



APW Wyott Foodservice Equipment Company

729 Third Avenue • Dallas, TX 75226 • 800-527-2100 • 1-214-421-7366 • Fax 1-214-565-0976

For more information e-mail us at: Info@APWwyott.com

Rev. 1/1/2003 #1503